



SUPPLEMENTARY REGULATIONS

from 17th to 19th of october



Rua General Humberto Delgado, 3
2685 - 340 PRIOR VELHO
Tel: 351 219 429 187 Fax: 351 219 429 192
acpmotorsport@acp.pt



INDEX		
	Past Winners	3
Article 1	Introduction	7
Article 2	Organization	7
Article 3	Programme	10
Article 4	Regulations	11
Article 5	Categories	12
Article 6	Licenses	15
Article 7	Entries	15
Article 8	Insurance	17
Article 9	Identification	17
Article 10	Advertising	18
Article 11	Training and Reconnaissance	18
Article 12	Itinerary	19
Article 13	Administrative Checks	19
Article 14	Scrutineering	20
Article 15	Service áreas and Refuelling	21
Article 16	Prologue/Reconnaissance/Fixed Penalty and maximum time of SS	23
Article 17	Briefing	25
Article 18	Starting Order	25
Article 19	Time Controls	26
Article 20	Selective Sections / Route Marking / TC / SS Interruption / Speed Control / Tyres / Neutralization / Other Procedures	26
Article 21	Safety	31
Article 22	Means of Communication	32
Article 23	Parc Fermé	32
Article 24	Protests / Appeals	33
Article 25	Prize List	33
Article 26	Prize Giving Ceremony	34
Article 27	Environment	34
Appendix I	Advertising Plan	35
Appendix II	Competitors Relation Officer (names and photographs)	36
Appendix III	Equipment	37
Appendix IV	Itinerary	38
Appendix V	Instructions for GPS/GSM Location and Security System, STELLA III (Moto, Quad and SSV)	40
Appendix VI	Safety Plan	52
Appendix VII	Service Parck Nerpor Layout	55
Appendix VIII	Environmental Policy	56

Honors (MOTO)

1987	1st Paulo Marques / Marcos Carvalho – Aprila RX 250 2nd António Lopes – Honda CR 250 3rd João Lopes - Honda CR 250	1988	1st António Lopes / João Lopes – Honda CR 250 2nd José Projecto / Bernardo Villar – Yamaha YZ 250 3rd Nuno Carido / Júlio Lopes – Honda CR 250
1989	1st João Lopes – Honda CR 250 2nd Gilles Lalay – Suzuki RMX 3rd António Lopes – Honda CR 500	nineteen ninety	1st António Lopes – Honda CR 500 2nd João Lopes – Honda CR 500 3rd Thierry Magnaldi – Yamaha YZ 250
1991	1st António Lopes – Honda CR 250 2nd Bernardo Villar – Honda XR 600 3rd David Castera – Yamaha YZ 250	1992	1st António Lopes – Honda CR 250 2nd Thierry Magnaldi – Yamaha YZ 250 3rd Cyril Esquirol – Husqvarna WR 250
1993	1st Carlos Crespo – Kawasaki KX250 2nd Paulo Marques – Honda CR 250 3rd António Lopes – Honda CR 250	1994	1st Paulo Marques – Honda CR 250 2nd Miguel Farrajota – TM Enduro 250 3rd Alain Perez – Kawasaki KX 250
1995	1st Richard Saint – Honda CR 250 2nd Paulo Marques – Honda CR 250 3rd Mário Brás – KTM LC4 620	1996	1st Alain Perez – Kawasaki KX 250 2nd Paulo Marques – Honda CR 250 3rd António Lopes – Husaberg FE 500
1997	1st Miguel Farrajota – TM 250 2nd Paulo Ascenso – Honda CR 250 3rd Nuno Duarte – Yamaha YR 250	1998	1st Rúben Faria – Yamaha WR 400 2nd Pedro Afonso – Honda 250 3rd Luís Serra – Yamaha YZ 250
1999	1st Rúben Faria – Yamaha YZ 400F 2nd Pedro Afonso – Kawasaki KX 3rd Miguel Farrajota – TM Enduro 250	2000	1st Luís Serra – Yamaha YZ 250 2nd Victor Azevedo – Honda CRE 250 3rd Pedro Afonso – Kawasaki KX 500
2001	1st Paulo Gonçalves – Honda CR 250 2nd Pedro Afonso – Yamaha WR426 3rd Sandro Marcos – Honda CR 250	2002	1st Luís Serra – KTM 520 EXC 2nd Paulo Gonçalves – Honda CRF 450 3rd Válder Martins – KTM 125 EXC
2003	1st Sandro Marcos – Suzuki 250 2nd Pedro Afonso – Yamaha WR 450 3rd Pedro Barradas – Honda CRF 450	2004	1st Mário Patrão – Yamaha WR 450 2nd Paulo Cardoso – Yamaha WR 450 3rd Joaquim Norte – KTM EXC 520
2005	1st Mário Patrão – Yamaha YZ 450F 2nd António Maio – Yamaha YZ 250 LC 3rd Paulo Gonçalves – Honda CRF 450	2006	1st Mário Patrão – Suzuki RMZ 450 2nd Rúben Faria – Yamaha YZ 450 3rd António Maio – Yamaha YZ 450
2007	1st António Maio – Yamaha YZ 480F 2nd Mário Patrão – Suzuki RMZ 450 3rd Tomás Neves - Yamaha WR 250F	2008	1st António Maio – Kawasaki KX 450 F 2nd Mário Patrão – Suzuki RMZ 450 3rd Fernando Ferreira – Yamaha YZ 450 F
2009	1st Mário Patrão – Suzuki RMZi 450 2nd António Maio – Kawasaki KXF 450 3rd David Megre – KTM EXC.F 250	2010	1st António Maio – Yamaha YZ 450 F 2nd Mário Patrão – Suzuki RMX - Z 3rd David Megre – KTM EXC 450 R
2011	1st António Maio – Yamaha YZ 450 F 2nd Luís Oliveira – Yamaha YZ 125 3rd Fausto Mota – Yamaha YZ 250 F	2012	1st António Maio – Yamaha YZ 450 F 2nd Mário Patrão – Suzuki RMZ 450 3rd Hélder Rodrigues – Honda CRF 450
2013	1st Mário Patrão – Suzuki RMZ 450 2nd António Maio – Yamaha YZ 450 F 3rd Pedro Afonso – KTM 500 EXC 510	2014	1st Mário Patrão – Suzuki RMZ 450 2nd António Maio – Yamaha YZ 450 F 3rd João Vivas – Suzuki RMZ 450
2015	1st Luis Oliveira – Yamaha YZ 2nd Mario Patrão – KTM 450 SXF 3rd Sebastian Bühler – Yamaha YZ 250F	2016	1st Luis Oliveira – Yamaha YZ 2nd Sebastian Buhler – Yamaha WR 450 F 3rd João Lourenço – Sherco SEF R
2017	1st António Maio – Yamaha WR 2nd Luís Oliveira – Honda RX 3rd Mário Patrão – KTM 450 EXC Factory	2018	1st Sebastian Buhler – Yamaha WR 450 F 2nd Bruno Santos – KTM EXC F 3rd Martim Ventura – Yamaha WR 250 F
2019	1st Sebastian Buhler – Husqvarna FC 450 2nd António Maio – Yamaha WR Rally 3rd Bruno Santos – Husqvarna FE	2020	1st Sebastian Buhler – Hero Hero 450 Rally 2nd Joaquim Rodrigues – Hero Hero 450 Rally 3rd Bruno Santos – Husqvarna FE 500
2021	1st António Maio – Yamaha WR450F 2nd Gustavo Gaudêncio – Honda CRF4 3rd André Sérgio – Yamaha WRF	2022	1st António Maio – Yamaha WR450F 2nd Martim Ventura – Yamaha WR450F 3rd Gustavo Gaudêncio – Honda CRF450RX
2023	1st Bruno Santos – Husqvarna FE501 2nd André Sérgio – Beta RR 300 Racing 3rd Gonçalo Amaral – Honda CRF 450		

QUAD

2000	1st Paulo Barbosa – Yamaha YFZ 350 2nd Jordi Saborit – Honda TRX 400 3rd Paulo Nobre - Honda TRX 400	2001	1st Mário Reis - Honda TRX 400 2nd Paulo Nobre - Bombardier GS 650 3rd Jorge Esperto - Bombardier GS 650
2002	1st Vítor Santos – Suzuki LT 400 2nd José Clemente - Honda TRX 400 3rd Paulo Nobre – Bombardier GS 650	2003	1st Jordi Saborit - Bombardier GS 650 2nd Vítor Santos – Suzuki LTZ 400 3rd Nelson Caxias – Polaris Predator 500
2004	1st João Lopes – Suzuki LTZ 450 2nd António Moreira – Polaris Predator 500 3rd Pedro Costa – Honda TRX 450	2005	1st Rui Fernandes – Honda TRX 450R 2nd Pedro Costa – Suzuki LTZ 400 3rd Alexandre Oliveira – Suzuki LTZ 400
2006	1st Nelson Caxias – Yamaha YFZ 450 2nd Luís Engeitado – Yamaha YFZ 450 3rd Simão Correia – Suzuki LTZ 400	2007	1st Vítor Santos – Suzuki LTR 450 2nd Paulino Cruz – Suzuki LTR 450 3rd João Lopes – Suzuki LTR 450
2008	1st Rui Mendes – Suzuki LTR 450 2nd João Peraboa – Suzuki LTR 450 3rd João Batista – Suzuki LTR 480	2009	1st Humberto Pinto – Suzuki LTR 450 2nd Roberto Borrego – KTM 525 XC 3rd João Lopes – Suzuki LTR 450
2010	1st Roberto Borrego – KTM 525 XC 2nd João Lopes – Suzuki LTR 450 Z 3rd Humberto Pinto – Suzuki LTR 450	2011	1st Roberto Borrego – YFZ 450 2nd António Moreira – Polaris Outlaw 525 3rd Vítor Santos – Kawasaki KFX 450
2012	1st Roberto Borrego – Yamaha YFZ 450 R 2nd Rui Cascalho – Yamaha YFZ 450 R 3rd André Mendes – Suzuki LTR 450 B	2013	1st André Carita – Suzuki LTR 450 2nd Vítor Santos – Yamaha 450 R 3rd Luís Enjeitado – Polaris MXR 450
2014	1st Luís Enjeitado – Yamaha YFZ 450 2nd Rui Cascalho – Yamaha YFZ 450 R 3rd Ricardo “Antrax” Carvalho – Polaris MXR 450	2015	1st Roberto Borrego – Yamaha YFZ 450R 2nd André Carita – Suzuki LTR 450 3rd Antonio Moreira – Yamaha YFZ 450R
2016	1st Roberto Borrego – Yamaha YFZ 450R 2nd Rodrigo Pagaiame – Yamaha YFZ 450R 3rd Vítor Caeiro – Yamaha YFZ	2017	1st Roberto Borrego – Yamaha YFZ 450R 2nd Filipe Fernandes – Kawasaki KFX 450R 3rd Vítor Caeiro – Yamaha YFZ-R
2018	1st Roberto Borrego – Yamaha YFZ 450R 2nd Jacinto Lourenço – Moto Start TR 3rd Pedro Silva – Yamaha YFZ	2019	1st Roberto Borrego – Yamaha YFZ 450R 2nd Ruben Alexandre – Yamaha YFZ 450 R 3rd André Carita – Suzuki LTR
2020	1st Ruben Alexandre – Yamaha YFZ 450R 2nd Fábio F. Ferreira – Yamaha YFZ 450 R 3rd Filipe Silva – Suzuki LTR	2021	1st Luís Fernandes – Yamaha YFZ 450R 2nd Luís Engeitado – Yamaha YFZ 450 R 3rd Flávio Gonçalves – Yamaha YFZ 450
2022	1st João Vale – Yamaha YFZ 450R 2nd Luis Fernandes – Yamaha YFZ 450R 3rd Filipe Silva – Suzuki LTR 450	2023	1st João Vale – Can Am Renegade XXC 1000 2nd Tomás Paulo – Yamaha YFF 450 3rd Fábio Ferreira – ATV Racing

UTV

2008	1st António Val – Dazon 1100 D 2nd João Nascimento/Nuno Soares – Dazon 1100 D	2009	1st Jorge Monteiro – Polaris RZR 800 2nd Nuno V. Uden/Miguel Chaves – Polaris RZR 800 3rd Rui Castanheira – FBF 1100
2010	1st Carlos Esteves/Hélder Amado – Polaris RZR 756 2nd Tiago Cunha – Rage R 140T 1049 3rd José Vitória/Luís Vitória – Polaris RZR-S	2011	1st Jorge Monteiro – Polaris RZR XP 850 2nd Marco Grilo – Polaris RZR 900 3rd Rui Serpa – Rage R140T 1050
2012	1st David Além – IPS R7 2nd João Lopes/Bruno Santos – IPS RZR 900 3rd Teófilo Viñaras – Polaris RZR 900	2013	1st Nuno Tavares – IPS RX 875 2nd Aristides Mafra – Polaris RZR 900 XP 3rd Roberto Viñaras/Cristobal H. – Polaris RZR 900
2014	1st João Lopes/Bruno Santos – Polaris RZR 1000 2nd Teófilo Viñarás – Polaris RZR 900 3rd Carlos Miranda/Luís Gomes – Polaris RZR 900	2015	1st João Dias/João Miranda – Polaris RZRXP1000 2nd Pedro Santinho Mendes – Polaris RZR 3rd João Lopes/Bruno Miguel – Polaris RZRXP

BUGGY

2010	1st António Val/Cristina C. – Dazon Re-1100D 2nd Pedro Ramilo/Alcides Calçada – Semog 1100 3rd Rui Castanheira – FBF Nani Ny 1100	2011	1st Gonçalo Porêlo/Rui Porêlo – Semog 1000 2nd Luís Ramalho – Nanyi NY 1083 3rd António Brás – FBF DS 1100
2012	1st João Guilherme - IPS R7 2nd Luís Caseiro - IPS R7	2013	1st António Ferreira/Hélder B. – Rage Sports 1300 2nd Daniel Russo/Luís Silva – Nanyi NY 1100 3rd Deborah Almeida – Dazon RE 1100
2014	1st Bruno Martins – Rage Comet R 1400 2nd João Lota – Dazon Jb Racing 1300 3rd Pedro Perino/Nuno M. – Rage Comet R 1400	2015	1st Daniel Russo – PRT Nanyi NY

UTV/BUGGY

2016	1st João Silva/Marco Silva – Yamaha YXZ 1000 2nd Pedro Mendes – Polaris RZR 3rd Stephane Peterhansel/Andrea P. - Yamaha YXZ
-------------	---

SSV

2017	1st Rúben Faria/Pedro Velosa – Can-Am Maverick X3 RS 2nd Stéphane Peterhansel/Andrea Peterhansel – Yamaha YXZ 1000S 3rd Bruno Martins/Eurico Adão – Can-Am Maverick X3 RS	2018	1st Marco Pereira/Eurico Adão – Can-Am Maverick X3 RS 2nd Vitor Santos/Gregório Pereira – Can-Am Maverick X3 XRS TURBO 18 3rd Dirk Von Zitzewitz/Andrea Peterhansel – Can-Am Maverick
2019	1st Pedro Carvalho/André Guerreiro – Can Am Maverick X3 2nd Santinho Mendes - Can Am Maverick X3 3rd João Monteiro/Manuel Pereira - Can Am Maverick X3 XRS	2020	1st João Dias – Can Am Maverick X3 2nd Alexandre Pinto/Fábio Belo - Can Am Maverick X3 3rd Roberto Borrego/Nuno Abrantes - Can Am Maverick X3 XRS
2021	1st Gonçalo Guerreiro – Can Am XRS 2nd Alexandre Pinto – Bombardier Can Am Maverick 3rd Armindo Araújo/Beatriz Pinto – Bombardier Maverick	2022	1st Gonçalo Guerreiro/Fernando Mendes – Can Am XRS 2nd João Monteiro/Nuno Morais – Can Am X3 3rd Luis Cidade/Pedro Mendonça – Can Am XRS
2023	1st Helder Rodrigues – Can Am Maverick 2nd João Monteiro/Nuno Morais – Can Am X3 3rd – Gonçalo Guerreiro/José Sá Pires – Polaris Pro R		



ART.1 – INTRODUCTION

1.1. The Automóvel Club de Portugal (ACP) organizes the 38th BAJA PORTALEGRE 500 from October 17th to 19th, 2024. This event is a part of the Portuguese Cross-Country Championship and occurs simultaneously with a car event (FIA World Cup for Cross Country Bajas).

And others:

- Yamaha YXZ1000R European Cup SuperFinale

Approved by FMP in: 30/07/2024

Modification, amendments and/or changes to these Supplementary Regulations will be announced only by numbered and dated Bulletins issued by the Organizer and approved by the FMP Jury.

1.2. Description of the Event

- October 16, accreditations and installation at Nerpor
 - 17 October, administrative and technical checks, recognition of the Prologue and departure ceremony;
 - October 18, 1st Stage, includes the Prologue, approx. 3.5 km and the SS1 of approx. 70 km
 - October 19, 2nd Stage, includes SS2 with around 300km.
- The route must be kept secret. Only SSVs have a Road Book for selective sectors. The route is marked with arrows, plastic tape and some other signs for Motorcycles and Quads.
- Motorcycles and quads have a Road Book, only for connections (Road Book Service). Refueling points (GAS) or Service Areas (ZA) will be placed every 85km, maximum.

The average altitude of the selective sectors is 500 meters.

1.3. Route Terrain

100% gravel/dirt tracks

ART.2 – ORGANIZATION

2.1 Organization Name, Address and Contact Details

Automobile Club de Portugal

ACP Motorsport

Rua General Humberto Delgado, 3

2685-340 Prior Velho – Portugal

Tel.: + 351 219 429 187

Fax: + 351 219 429 192

Email: acpmotorsport@acp.pt

Web site: www.acp.pt



**AUTOMÓVEL
CLUB DE PORTUGAL**

Rua General Humberto Delgado, 3
2685 - 340 PRIOR VELHO
Tel: 351 219 429 187 Fax: 351 219 429 192
acpmotorsport@acp.pt



2.2 Event Location

NERPOR

Campo da Feira

7300 Portalegre

Phone: +351 219 429 187

Fax: +351 219 429 192

E-mail: acpmotorsport@acp.pt

Website: www.bajaportalegre500.com

GPS: N 39º 16. 394' – W 07º 25. 266'

2.3 Official Posting Board

October 17th to 19th:

www.bajaportalegre500.pt

Sportity

Password: **BAJA500MOTO**

2.4 Secretariat

- Until October 15th at the ACP Motorsport facilities in Prior Velho (Art. 2.1), from 9:00 am to 6:00 pm
- From October 16th to 19th at NERPOR (Art. 2.2)

2.5 Organizing committee

Chairman	Carlos Barbosa
Vice president	Marta Barbosa
	João Mendes Dias
	João Jordão
Route Director	Orlando Romana
Route Supervisor	Jaime Santos
Secretary of the Event	Vanda Marcelo

2.6 Test Jury

President	José Rita TBA
FMP member	Diogo Rodrigues
Organizer Member	Eduardo Rovisco
Jury Secretary	TBA

2.7 Technical Delegates

FMP Technical Delegates	TBA
	TBA

2.8 Senior Officials

Clerk of the course	Márcio Santos
Deputy Clerk of the course	Orlando Romana
	Eduardo Rovisco
Chief Safety Officer	Jaime Santos
Chief Medical Officer	Dr. Pedro Barradas
Secretary of the Event	Vanda Marcelo
Environmental Officer	Bruno Silva Gomes
Responsible for Logistics	Nuno Vieira
Press Officer	Marco Barbosa
Timekeeping	Anube
Scrutinner's	Eduardo Rovisco
	Claudio Pedroso
	João Rovisco
	Tiago Martins
Competitors Relations Officer	Eduardo Rovisco
	TBA
Service Park Coordinator (NERPOR)	Filipe Santos
Service Areas (ZA) and GAS Coordinator	Hugo Lourenço

2.9 Officer IDs

Clerk of the Course	White Shirt
Timekeepers	Blue tabard
Safety Marshals	Yellow tabard
CRO	Red tabard
Scrutineers	Black tabard
Medical	Identified blue clothing
Media	Green tabard



August 1st (Thursday)		
18h00	Opening of Entries with promotional value	Website
	Publication of the Rally Guide	Website
	Publication of the Supplementary Regulation	Website

September 9th (Monday)		
18h00	Closing of Registrations with promotional value	Website

September 25th (Wednesday)		
18h00	Final Closing of Registrations	Website

October 9th (Wednesday)		
18h00	Publication of the Registration List	Website/Sportity

TEST WEEK

October 16th (Wednesday)		
10h00/22h00	Team Accreditations	Stadium

October 17th (Thursday)		
07:00/20:00	Accreditations	Stadium
07:30/21:30	Secretariat opens	Nerpor
08:00/14:00	Administrative checks <i>Delivery of written briefing</i>	Nerpor
09:00/15:00	Scrutineering	Nerpor
10h00/19h30	Media Accreditation	Stadium
10h00/19h30	Media Center opens	Nerpor
10h00/16h00	Reconnaissance of the Prologue, road book available on the race website and on Sportity from 9:30 am	Coutadas
18h00/20h00	Delivery of SSV Road Book for Sections 1 & 2	Nerpor
16h00	1st Meeting of the Jury	Nerpor
16h30	Briefing on Anube equipment (Stella III)	Nerpor
18h00	Publication of the starting list for the Ceremonial Start	Website/Sport
	Publication of the starting list for Stage 1	Website/Sport
19h00	Ceremonial Start	Portalegre
20h30	Press conference	Jardim do Tarro

October 18th (Friday)		
07h00/21h30	Secretariat opens	Nerpor
08h00/13h00	Accreditations	Stadium
08h00/13h00	Media Accreditation	Stadium
08h00/20h00	Media Center opens	Nerpor
07h20	Start of the Stage 1, Section 1	Nerpor
07h45	Prologue	Coutadas
09h00	Publication of the Prologue classification	Website/Sportity
09h30	Publication of the starting order for Section 2	Website/Sportity
10h15	Start of the SS1	TBA
11h00*	Arrival of the SS1	TBA
13h00/16h00	Delivery of Section 3 Road Book (SSV)	Nerpor
15h00*	Arrival of the Stage 1	Nerpor
17h30	2nd Meeting of the Jury	Nerpor
18h30	Publication of Stage 1 results	Website/Sportity
19h00	Publication of the starting order for Stage 2	Website/Sportity

October 19th (Saturday)		
06h15/22h00	Secretariat opens	Nerpor
07h00/21h00	Media Center opens	Nerpor
08h40	Start of the Stage 2	Nerpor
09h45	Start of the SS2	TBA
13h45*	Arrival of the SS2	Coutadas
14h15*	Arrival of the Stage 2	Nerpor
16h45	Podium Ceremony	Nerpor
18h00	3rd Meeting of the Jury	Nerpor
18h30	Publication of the provisional classification	Website/Sportity
19h00	Publication of the final classification	Website/Sportity
19h30	Prize Giving ceremony	Nerpor

* Expected time

3.1 Detailed times and locations of checks, start, arrival and prize ceremony will be published in a supplement.

The official time of the test will be GPS time (UTC time + local offset).

ART.4 – REGULATION

In case of divergences in the interpretation of this regulation, only the Portuguese text will be considered. This regulation and the FMP regulation will be considered.

It is considered essential to obtain, from the Portuguese Motorcycling Federation, the Regulations for the 2024 Open Cross-Country National Championship, as well as the Regulations for the various existing Trophies and Cups.

Portuguese Motorcycling Federation

Largo Vitorino Damásio, 3C, pavilion 1

1200-872 Lisbon

Tel.: +351 21 393 60 30

Fax: +351 21 397 14 57

Web site: <http://fmp-live.pt/>

ART.5 – CATEGORIES

MTT1	Bikes 2T	Up to 125 cc
	Bikes 4T	Up to 250 cc
MTT2	Bikes 2T	Equal to or greater than 150 cc up to 249cc
	Bikes 4T	Equal to or greater than 250cc up to 449cc
MTT3	Bikes 2T	Equal to or greater than 250cc
	Bikes 4T	Equal to or greater than 450cc
MTT 4*	Trail ou Big Trail	Bikes between 170kg / 210 kg
MTT5*	Maxi Trail	Bikes with more de 210kg
ME	Electric Bike	
QUAD	Quad	2 and 4 driving wheels
SSV	Atmospheric engines less than 2000cc or turbocharged engines less than 1000cc	
SSV TT2	Atmospheric engines less than 1000cc	
SSV STOCK	Atmospheric engines less than 2000cc or turbocharged engines less than 1000cc	

- A special classification will be created for motorcycles up to 50cc.

ART.6 – LICENSES

6.1. Rider's Licences

According to Art. 70.2.1 of FIM Sporting Code and according to Art. 5 of the FMP Regulations.

ART.7 – ENTRIES

The competitor enters the 38ª Baja Portalegre 500, in full awareness of the risks that he/she may take by participating in this event.

He/she agrees to indemnify, protect and hold harmless the Organizers, the FMNR and the FIM and anyone acting on their behalf or under their authority, including but not limited to their representatives, employees, agents, officials and volunteers, from and against any and all liability, penal and/or civil, loss, expense or claims of whatsoever nature, including but not limited to third party claims, relating to injury to persons, including death, or loss or destruction of or damage to property arising in connection with his/her participation in the 38ª Baja Portalegre 500.



Registration is limited to **300 competitors:**
180 Motorcycles, 40 Quad, 80SSV

7.1. Entries procedures

Registration is online and available on the test website:
www.bajaportalegre500.com

The truth and legality of the documentation provided by competitors is of his/her responsibility. The submission of false documentation will lead to the immediate exclusion of the competitor and possible disciplinary proceedings by FMP.

When entry, the following documents must be attached or sent by October 9, 2024, to the Organizer:

- Pilot identification document (and co-pilot when applicable)
- Authorization to participate in the event when the sports license is from a foreign country
- Sports license
- Driving license
- Vehicle document
- Vehicle insurance

7.2. Entry Fees

Vehicle	Registration fee until September 9th	Registration fee from September 10st to September 25th
Motorcycle / Quad	€655	€982
SSV	€1500	€2250

*** 23% VAT is added to the registration fee at the legal rate**

Competitors who refuse the organization's optional advertising will have a 100% increase in the registration fee.

Information regarding VAT:

- Invoices issued in the name of foreign companies are not subject to VAT (Reverse charge VAT).
- Invoices issued in the name of an individual of any nationality or in the name of Portuguese companies are subject to VAT, which will add a rate of 23% to the registration value mentioned above (VAT value in Portugal)

Payment methods: PayPal, Credit Card and ATM and transfer:

Bank: BPI

Account Holder: Automóvel Club de Portugal

IBAN: PT50001000002673878001239

BIC: BBPIPTLP



**AUTOMÓVEL
CLUB DE PORTUGAL**

Rua General Humberto Delgado, 3
 2685 - 340 PRIOR VELHO
 Tel: 351 219 429 187 Fax: 351 219 429 192
 acpmotorsport@acp.pt



The entry fee includes:

Included in the entry fees
Insurance of civil liability towards third parties
1 BIKE / QUAD sticker (access to Nerpor and the Services Areas)
1 SSV sticker (access to Nerpor and the Service Areas)
1 TEAM MANAGER sticker (access to Nerpor, Services Areas, and Start / Arrival of the SS)
1 Competitor(Bike/Quad) or 2 Competitors (SSV) Individual Pass
1 Team Manager individual passes (access to Secretariat)
4 Service individual passes
Rental of Anube STELA III equipment (Vehicle to vehicle communication system, speed control zones, and GPS-GSM / Safety tracking system)
Road Book roll or notebook for SSV (upon competitor's choice at time of registration)

Additional plaques and passes:
€600 – Truck
€400 - Auto / Van

- 7.3** Registration will be considered void if it is not accompanied by the corresponding registration fee.
- 7.4** The organization reserves the right to refuse registration to drivers or teams that have been disqualified in previous editions of the race for unsportsmanlike behavior.
- 7.5** The organization will reimburse a variable part of the registration fee to competitors who, for reasons of force majeure, are unable to present themselves at the start of the race, provided that the fact is communicated to the organization by registered letter.

Entry fee refunds:

- 25% of the registration fee, in the case of a communication received at least 30 days before the date of verifications;
- 50% of the registration fee, in case of communication received at least 8 days before the date of verifications.
- There will always be a retention of 25% of the registration fee (handling fee).

Other situations of force majeure not mentioned here are subject to analysis by the Organizing Committee.

ART.8 – INSURANCE

According to art. 110.1.1 of the FIM Sporting Code

- 8.1 The Automóvel Club de Portugal, as well as the Organizing Committee of the event, decline all responsibility for any accidents that may occur during the 38th Edition of the Baja Portalegre 500.

ART.9 – IDENTIFICATION

- 9.1. The organization will provide each driver with three panels containing the competition numbers, as well as two advertising boards and a race number with the proof number. It is not permitted to cut out the test numbers, they must be placed exactly as they are received. Failure to comply with this rule prevents technical checks from being carried out.
- 9.2. The panels and plaques must appear, throughout the race, in accordance with the advertising placement scheme (Appendix I). **The use of the bib is mandatory throughout the race.**
- 9.3. If at any moment of the event, of the lack or incorrect placement of a panel, plaque or bib will result in a penalty of:

1st Offense	1 hour
2nd Offense	Disqualification

- 9.4. An identification bracelet will allow you to recognize the pilots. This bracelet will be placed at the accreditation location (**next to the football stadium, close to NERPOR**), and cannot be removed until the end of the race or until the moment the pilot has given up or been disqualified. The discovery, at any time of the race, that the bracelet is missing will result in disqualification.

ART.10 – ADVERTISING

- 10.1. The spaces reserved for the organizer for mandatory and non-negotiable advertising are (see Appendix I):
- 3 Plates 18x22 cm plaques with competition numbers
 - 1 Bib (30x30 cm cloth plate) to be placed on the rider's dorsal area. Free fixation
 - 2 Race Plates (10x21 cm)
 - **SSVs must place two fixed vertical plates at the rear of the vehicle, on both sides, in accordance with Art. 10.4 of the FMP RCNTT**

Plates and bibs provided by the organization cannot be altered (cut, etc.) and must be visible and legible throughout the duration of the race.

10.2. Mandatory advertising: BP / PORTALEGRE / PONTE DE SOR

ART.11 – TRAINING AND RECOGNITION

- 11.1. The start will be refused to competitors already registered or who will register, detected by members of the organization, authorities (GNR, BV, Civil Protection and Judges of Fact) or by the owners of the properties used by the race route, circulating in the area of the race (on dirt roads), with any vehicle

(Motorcycle/Quad/SSV or Car) in the 30 days prior to the start of the race, according to article 2.12 of the RCNTT.

The area where the race will take place is included in the municipalities of: Alter do Chão, Abrantes, Crato, Chamusca, Gavião, Monforte, Nisa, Ponte de Sor and Portalegre.

Participants in the race who reside in the municipalities mentioned above are obliged to comply with the same requirements as the rest, except if it is proven that for professional or special reasons they have to travel along existing dirt paths.

ART.12 – ITINERARY

- 12.1. It is absolutely prohibited, under penalty of up to disqualification, to be decided by the race Jury, to drive outside the race itinerary (Road Book and/or markings), except when it is blocked. In this case, drivers must pass alongside the obstacle and return to the track immediately after it.

Participants in the 38th Baja Portalegre 500 will be monitored by Stella III control equipment. The official route of the race is defined by the Road Book, for SSV, and by the signage, for motorbikes/quads, placed on the ground, using existing rural and/or forest paths. Compliance with the official route is mandatory, under penalty of penalties .

The calculation of the difference in distance (in meters) between the official route and the route taken by the competition vehicle incurs a penalty calculated as follows;

- For each unit of distance (meter) calculated as the difference between the official route and the route covered by the competitor, a penalty of 10 seconds is applied.

Riders must maintain an attitude of respect for the environment, forest and private paths, agricultural properties, and comply with the highway code when traveling on public roads.

ART.13 – ADMINISTRATIVE CHECKS

13.1. Location and hours

Administrative checks will take place on October 17th, according to the test program. The place and time will be indicated by addition.

Please note that the veracity of the information provided by the competitor is your sole responsibility. If false documentation or incorrect information is found to be used, the pilot in question will be immediately excluded from the race and other sanctions may be applied by the FMP.

13.2. Administrative checks will verify:

- FIM Sports License (Art 6.1) or FMP
- Pilot Identification Document (CC or Passport);
- Authorization documentation from the vehicle owner (if not the owner);

Delivery of the installation kit for the Stella III.

Applications that have not been completed in full, with all the requested elements, will receive different and possibly delayed processing.

13.3. Any delay in relation to the established call time will result in the following penalties:

From 1 to 15 minutes	€150 fine
From 16 to 30 minutes	€250 fine
More than 30 minutes	Participation refused

ART.14 – SCRUTINEERING

14.1. Location and hours

Technical checks will take place on October 17th, according to the race program. The place and time will be indicated by bulletin.

14.2. In scrutineering for motorcycles and quads (Art. 26.2 of the RCNTT) will be controlled:

- Advertising placement;
- Number plates;
- Front and stop lights with fixed and definitive installation (must be powered at all times by an alternator driven by the motorcycle engine);
- Registration;
- Frame number (must match the booklet or unique document);
- Protection pad located in the middle of the handlebars;
- Helmet.
- Front and back protection vest

- Installing the Stella III Kit
Noise control may occur.

14.3. In the scrutineering of the SSV (Art. 26.2 of the RCNTT) it will be controlled:

- Technical passport
- Advertising placement;
- Competition numbers on the side (they must be placed on a “quad flag” which must be fixed at the highest point of the vehicle structure) or on the rear.
- Front and stop lights with fixed and definitive installation and turn signals
- Current cut-off operation;
- Fitting seat belts;
- Placement of lateral protection nets;
- Registration;
- Frame number (must match the booklet or unique document);
- Helmets);
- Hans;
- Fire extinguishers;
- Clothing.
- Installing the Stella III Kit

Noise control may occur.

14.4. Any delay in relation to the established call time will result in the following penalties:

From 1 to 15 minutes	€150 fine
From 16 to 30 minutes	€250 fine
More than 30 minutes	Participation refused

14.5. After the verification operations, the drivers will be given time to complete the connection sector to the Parc Fermé that precedes the Starting Ceremony, the vehicle can be driven by any member of the team.

14.6. Any delay in presenting to Parc Fermé after the Technical Checks will result in the following penalties:

From 1 to 15 minutes	€150 fine
From 16 to 30 minutes	€250 fine
More than 30 minutes	Participation refused

14.7. Any competitor who refuses to make their vehicle available to the Technical Commissioners for possible verification during the race or upon arrival, may be penalized with disqualification, after analysis and decision by the Race Jury.

14.8. It is up to the rider, in the event that identification marks have been placed on the motorcycle, to verify under his sole responsibility that they will remain intact until the end of the race. The lack of any mark will result in immediate disqualification.

- 14.9. Without this constituting an obligation, a complete and detailed check, providing for the dismantling of the motorcycles of the teams ranked first in the general classification and in each class, as well as any other vehicle, may be carried out by determination of the Jury or following a complaint or on the advice of the Race Director.

ART.15 – SERVICE AND REFUELING

THE MAXIMUM SPEED ALLOWED IN SERVICE AREAS (including NERPOR) and GAS AREAS IS 30 KM/H.

Speed control will be carried out by Stella III equipment (SSV, Motorcycle and Quad) Appendix V.

- 15.1 Service is allowed:

- a) Throughout the route:
 - By the pilot himself,
 - By another driver, regularly registered and still in the race;

- b) In the Service Zones (ZA) of the selective sectors (SS) made available by the organization:
 - By the pilot himself,
 - By another driver regularly registered and still in the race
 - By other people traveling in vehicles identified with plates provided by the organization.

- c) At NERPOR and in the Connection Sectors (from Parc Fermé to SS Departures and from SS Arrivals to Parc Fermé):
 - By the pilot himself,
 - By another driver regularly registered and still in the race
 - By other people traveling in vehicles identified with plates provided by the organization. (in this case, service is prohibited in the 3km before the start of an SS, and in the first 3km after the end of the SS).

Any infraction of the service rules will result in a penalty to be decided by the race Jury..

- 15.2 The use of an environmental mat is mandatory in Service and refueling operations (art. 15.3 of the RCNTT). Failure to use the environmental mat will result in a 5-minute penalty.

The use of these mats in the parc ferme is mandatory.

Service must have a fire extinguisher weighing at least 5 kg available (art. 15.9 of the RCNTT)

- 15.3 The location of the Service Zones (ZA) and/or Refueling Zones (GAS), which will be a maximum of 85 km apart, will be indicated during the Briefing or in the information distributed during adm checks. The distance to each Service Zone will be marked

along the route by means of signs, every 10 km, indicating the number of kilometers, in decreasing order, to travel to the next Service Zone.

- 15.4** There will be a limited time service at the end of the 1st Stage, at Nerpor, after SS1 (3h00).

The 3 hours begin at the entrance to the Service Zone (time control 1B, Door 2 of the Layout in Appendix VII) and end with the entry into the Parc Fermé.

- 15.5** Service Vehicles will be admitted to the Service Zones, as long as they have the plates provided by the organization (the plate must be visibly placed in the upper part of the windshield).

Each driver, in the corresponding category, will receive 1 plaque free of charge:

- **SERVICE BIKE / QUAD**, allows access to NERPOR and the ZA and GAS along the route.
- **SERVICE SSV**, allows access to NERPOR and the ZA and GAS along the route.
- **TEAM MANAGER**, allows access to NERPOR and the ZA and GAS on the route and also to SS departures and arrivals.

If counterfeit plates are found to be used, the competitor corresponding to the team will incur a penalty that could go as far as disqualification.

- 15.5** Refueling with the engine running is expressly prohibited.

Failure to comply with this rule will result in a 30-minute penalty and, in the event of a repeat offense, disqualification.

- 15.7** Refueling outside the areas provided for service, ZA or GAS is expressly prohibited. Failure by members of the organization to comply with this article will result in disqualification.

- 15.8** The transport of fuel in tanks not fixed to the structure of the vehicle is prohibited, resulting in a 30-minute penalty and, in the event of a repeat offense, disqualification.

- 15.9 For SSV, Moto or Quad**, according to Art. 15.1 of the RCNTT, in any Service Zone or GAS located in the SS, **refueling is carried out in a TRANSFER zone with a minimum of 3 minutes at each location.**

During refueling, no other intervention on the vehicle is permitted.

- a) The Stella III equipment shows the 2-minute countdown on the screen.
- b) The engine must be turned off when refueling or servicing the vehicle.
- c) Failure to comply with the rules, a) and c) incurs a 10-minute penalty for each infraction.

There are no Assistance Zones (ZA) in the selective sectors, only Refueling Zones (GAS).

GAS	BIKE/QUAD/SSV
GAS 1	80
GAS 2	160
GAS 3	230
Final / Arrival SS2	300

In GAS Zones, fuel supply, delivery of drinks, food as well as glasses and gloves are permitted. Any other intervention is not permitted and is subject to penalties to be awarded by the Trial Jury.

ART.16 – PROLOGUE / RECONNAISSANCE / FIXED SS PENALTIES / MAXIMUM SS TIME

- 16.1** In day18, a Prologue with a length of around 3,5 km and SS 1 with a length of around 70km. The time obtained in the Prologue will be used to define the starting order of SS1.
The reconnaissance of the Prologue It can be carried out according to the race program, on the 17th, between 10:00 am and 4:00 pm on foot, by normal bicycle or electric bicycle.
- 16.2** It is absolutely prohibited to cut or shortcut the route, and riders must follow the route indicated by the arrows and plastic bands. Failure to comply with this rule will result in a penalty awarded by the Test jury.
In the event of a track departure, drivers must return to the race in the same location.
- 16.3** If the track is obstructed, the pilot will be able to leave the track to go around the obstacle and return to the track immediately after it. No cancellations will be permitted nor will any discounts be granted in relation to the time spent traveling the itinerary. Under no circumstances will a repetition of the Prologue.
- 16.4** The maximum time for The Prologue will take 30 minutes.
- 16.5** The time of the Prologue counts for the purposes of establishing the final classification of the test.
- 16.6** In case of a tie In the Prologue, pilots with the same recorded time will depart for SS1 in numerical order.
- 16.7** The hypothetical penalties recorded in the Time Controls installed during the 1st stage will not influence the Prologue standings and starting order for SS1.
- 16.8** a) If a pilot does not complete the Prologue within the regulatory 30 minutes, he will be given the maximum time to complete it (30 minutes).

b) If a pilot does not participate in the Prologue, he will be given the maximum time to complete it (30 minutes), plus a fixed penalty of 30 minutes.

c) Even so, and in any of the circumstances mentioned above, you will be authorized to leave for the next SS as long as you present yourself at the park closed before it, up to 10 minutes before its scheduled time and as long as you inform the organizer (relations with competitors, via email crobike.bajaportalegre@acp.pt, or telephone, see Appendix II) of your intention to

participate in the next SS up to 30 minutes before the scheduled publication of the list with departure times (according to the race program).

This rule also applies to faults in connection sectors as long as the aforementioned procedures are followed.

d) If a pilot does not complete SS1 within the time limit for that purpose, he will be allocated the maximum time defined for completing SS1 plus the times of planned connections not made plus a fixed penalty of 60 minutes.

e) If a pilot does not participate in SS1, he will be allocated the maximum time defined for completing SS1, plus the times of planned connections not made, plus a fixed penalty of 120 minutes.

f) Even so, and in any of the circumstances referred to above, you will be authorized to leave for the 2nd Stage, as long as the respective vehicle enters the Parc Fermé (Nerpor), during its normal opening hours, or within 10 minutes before the start time. of the first competitor (motorcycle/quad or SSV) for the start of the 2nd Stage and as long as he informs the organizer (relations with competitors) of his intention to

participate in the next stage up to 30 minutes before the time scheduled for publication of the list with the departure times for the start of the stage.

g) In any of these cases, riders will have to start the 1st stage, that is, remove the bike from Parque Fechado on the 27th (Nerpor).

If this is not possible, the competitor must make a request to the Race Jury, requesting participation in the 2nd stage, even if they do not remove the motorcycle from the Parc Fermé in the 1st stage. If accepted, a penalty to be defined by the Jury will be applied, which will always be higher than those for the cases mentioned above.

The pilots covered by this rule will leave for the respective selective sector or stage after the classified pilots, in ascending order of their competition numbers.

16.9 Any case of a tie at the end of the race will be decided in favor of the competitor who achieved the besttime in the Prologue. If a tie still prevails, priority will be given to the first driver to achieve the best time in the Prologue.

16.10 Maximum Time and Fixed Penalties in SS

SS	km	Maximum Time	Fixed Penalty
Prologue	3.5	30m	30m
SS1	60	80m	60m / 120m
SS2	300	400m	120m

ART.17 – BRIEFING

17.1 The briefing will be written and delivered at administrative checks, and available on the official website and Sportity.

According to the program, a Briefing on Anube, Stella III equipment will be held at the administrative checks location.

ART.18 – START (ORDER AND INTERVAL) AND LIAISONS

18.1 The start for the 1st Stage and the Prologue will be given in ascending order. The Motorcycles come first, followed by the Quads and lastly the SSV. There will be 5 minute breaks between groups.

The Baja Promotion and Hobby classes will depart at the end of each Group; Motorcycle; Quad; SSV.

18.2 Start for SS1 will be given in Prologue seed order. Penalties from Time Controls installed during the 1st Stage will not influence the starting order of SS1. The Motorcycles come first, followed by the Quads and lastly the SSV. Departure intervals will be published in addition.

18.3 The start for the 2nd Stage will be given depending on the classification obtained with the sum of the results obtained in the Prologue and SS1 plus hypothetical sports penalties (SS) and penalties recorded in time controls during the 1st Stage. Motorcycles come first, followed by Quads and, lastly, SSVs. The Baja and Hobby Promotion Classes will depart according to the posted program and timetable, in a system to be defined and will cover a sector of around 150 km. The Race Director may, for reasons of force majeure, change the expected order.

18.4 Liaisons and transport

Liaisons must be made with competition vehicles. The transport of competition vehicles on trailers or vans is prohibited, except when explicitly authorized.

18.5 Any delay in the presentation at the start of any of the Stages (leaving the Parc Fermé) will be penalized with one minute for each minute of delay. A maximum delay of 15 minutes will be allowed. Any rider who shows up late will be refused departure.

ART.19 – TIME CONTROLS

In accordance with Art. 20 of the RCNTT of the FMP

ART.20 – SELECTIVE SECTORS / ROUTE MARKING / PASSAGE CONTROL / SS INTERRUPTION / SPEED CONTROL / TIRES / NEUTRALIZATION/ TRANSFER / OTHER PROCEDURES

- 20.1** During the Selective Sectors, service may be provided under the conditions set out in article 15 of this regulation.
- 20.2** Any pilot who refuses to leave for a Selective Sector at the time and in the order indicated will incur sanctions that could go as far as disqualification.
- 20.3** A maximum time will be established to travel through each Selective Sector. This time will be communicated by amendment. Exceeding this maximum time will result in disqualification.
- 20.4** The closing time of the different controls in a Selective Sector will be calculated as follows:

$$T_n = T_o + T_m + 60 \text{ minutes}$$

T_n : Control End Time "n"

T_o : Starting point of the last vehicle

T_m : Maximum Time in Control "n" calculated according to the distance from the start and the minimum average speed established for the race)

20.5 Route marking

For Motorcycles and Quads, Road Books will be distributed solely to carry out the connection sectors. SS routes will be indicated with arrows, plastic tape and paintings. Road Books (notebook or roll) will also be distributed to SSV students, if requested at the time of registration.

To make this appointment, the following criteria will be used:

- Placement of a **red sign with a white arrow** approximately 100 m from the direction change
- Placement of a **yellow sign with a black arrow** at the direction change location
- Placement of **red plastic tape, with the "ACP" logo**, on the right side of the course (in case of mistake, when the competitor returns to the track, the placement of the tape quickly indicates the direction to follow)
- Placement of **red and white plastic tape to define danger zones**
- Placing **signs with information about various types of danger (potholes, barbed wire, rocks, streams, bumps, etc.)**
- Placing signs with various information (CC, organization radios, CP, distance to ZA, etc.)
- Placing signs informing the approach (ZCV / 200m), the beginning (ZCV) and the end of the controlled speed zones (ZCV).

20.6 Crossing Controls (CC)

- a) Crossing Controls will be installed at intersections with tar roads or busy roads.
- b) These controls will be signaled with a sign (CC) at the intersection location.
- c) Pilots are obliged, under penalty of disqualification, to respect the Stewards' signals. Stopping the vehicle is mandatory, unless otherwise instructed by the flight attendant.

20.7 Passage Controls (CP)

- a) In order to check that riders respect the race itinerary, passage controls may be installed along the route.
Of these controls, some may be **mandatory stop** for all competitors.
- b) The control zone will be indicated with the usual regulatory panels:
 - Yellow with stamp (start of zone)
 - Red with stamp (exact location of control)
 - Beige with 3 black transverse bars (end of zone)
- c) Competitors may enter the Passage Controls at any time during the race (within the limits announced in article 20.4 of these regulations).
Passing through control will be recorded on a plastic letter or card with a stamp.
- d) In mandatory stop controls, a controlled speed of 30km/h will be applied from the beginning of the stop (sign with yellow clock) to the end (sign with diagonal bars).

Presenting the card at controls (CP) is the responsibility of each rider, attaching it to the bike or in any other way is also the rider's responsibility, failure to present the card at a Passage Control incurs a 2-minute penalty per control . In case of lack of a control card, registration will be made on the bib number.

In both cases, it is the pilot's responsibility to ensure that the visa placed by the controller, which validates the passage and stop at the control, is placed in a visible and permanent location.

- e) Failure to pass a passage control will result in disqualification.
- f) Stopping at the controls and confirming the visa placement is the responsibility of the pilot, who, for not stopping at a crossing control, will suffer the following penalties:

1st Offense	5 minutes
Subsequent infractions	10 Minutes for each Infraction

- g) The number and location of the various Passage Controls will be indicated by addition.

20.8 Disruption of a Sector Selective

In accordance with the spirit of this type of competition, the teams will be subject to unpredictable factors that will have to be overcome by each of them. In particular, if the route is totally or partially obstructed by any obstacle (for example, a vehicle or a very crowded river), it is up to the teams that then arrive at the scene to try by all means to clear the track and help teams in trouble.

With the use of the Anube system, once the facts have been proven, each competitor will be deducted from the time spent on site to clear the track.

However, considering the specific conditions of this event, of the low type, and in absolutely exceptional cases, such as a serious accident,

profound change in atmospheric conditions or any other extraordinary nature, the race may be interrupted, definitively or not.

If this happens, the following procedures will be adopted:

20.9 Within a Selective Sector, the route between two successive passage controls, or between two CCs (use of the Anube system), will be defined as a Subsector. The entire part of the Selective Sector route between:

- a) The Start Time Control for the Selective Sector and the first Passage Control or CC;
- b) Two successive Passage Controls, or CC;
- c) Any Control (Starting or Passing) and a possible Time Control (emergency) installed by decision of the Race Direction, for the purposes of Regrouping or Neutralizing the race;
- d) A new Start Time Control (emergency) resulting from the Neutralization of the race (following the provisions of the previous paragraph) and the Control (Passage or Arrival) immediately following.
- e) The last Passage Control installed and the Selective Sector Arrival Time Control.

20.10 The provisions of article 20.8 may be applied:

- a) To the entirety of a Selective sector, if no passage control has been installed there;
- b) Only in a specific subsector.

20.11 In the case provided for in art. 20.8, the Jury will determine that, for the classification of the Selective Sector, the sum of the actual times recorded will be considered, for competitors who were unable to cover the Subsector under normal competition conditions:

- Between the Selective Sector Departure Time Control and the Passage Control where the race was interrupted;
- Between the new Departure Time Control and the Selective Sector Arrival Time Control;

20.12 Competitors who have completed the entire Selective Sector (without any interruption) will only be awarded the actual total time recorded between the departure time control and the arrival time control of the Selective Sector.

20.13 If the Race Jury, for reasons of force majeure, decides to cancel a Subsector in which it is found that sporting truth has not been respected, the classification of the Selective Sector will correspond to the sum of the actual times recorded:

- Between the Departure Time Control and the Passage Control immediately before the place where the race is interrupted;
- And between the Passage Control immediately following the place where the race is interrupted and the Selective Sector Arrival Time Control.

In this case, a new departure must be made for the Selective Sector at Passage Control immediately following the location of the interruption.

For competitors who have completed the entire Selection Sector without interruptions, the actual time recorded for each of them between the Passage Controls located immediately before and after the place of interruption must be deducted from their actual total time recorded.

20.14 These procedures may be adopted regardless of the number of teams that have completed the route under racing conditions or that have been affected by the interruption of the race, that is, whether or not they have passed the obstacle or change of track that led to the blocking of other competitors.

20.15 Permitted early check-in

V4 (parc ferme in Jardim do Tarro after technical checks), TCCS1, TCP1A, TC1B, TC1C, TC2B

20.16 Classification

The final classification will be published on the official board and website:

www.bajaportalegre500.com

and on the Sportity

20.17 Speed Control Zones

To control these areas, the Anube Stella III system will be used. The start of the speed zone control will be indicated in the Road Book by a box marked "SZ" and the maximum authorized speed. The end of the speed control will be indicated in the Road Book by a box marked "FZ". Panels will also be placed at the beginning and end of each zone, along with others, informing the maximum speed allowed. These panels are for reference only, they have no regulatory validity, the information given by Anube equipment will prevail.

20.18 Speed Control Zones Sanctions

In accordance with Art. 14.5 of the RCNTT.

20.19 Tires

In accordance with Art. 47.05 of the Bajas FIM Technical Regulation.

For BAJA PROMOTION and HOBBY classes, which may use non-approved tires, with a maximum of 13 mm of tread (new or used).

20.20 Neutralization / Transfer between SS subsectors

The final time of a SS subsector is taken by the Stella III and Spica III equipment. Departure to the next subsector, **It is the pilot's responsibility.**

Procedures:

The Stella III or Spica III will indicate, in descending order, the Spica III to the minute and the Stella III to the second, with the last minute in both being the second. The authorized time between the end of the subsector and the location of the yellow starting sign located 100m from the start of the next subsector.

Starting signs will be placed in the starting area (red sign with black flag).

Between the yellow sign and the red sign, competitors can only access 1 minute before their starting time.

Competitors must place themselves at the starting line and must only proceed there when the Stella III or Spica III equipment displays the word "GO".

Early departures are subject to the following penalties by the Competition Jury:

The remaining Neutralization/Transfer time will be allocated, another minute of penalty.

This procedure will be observed by members of the organization present on site.

Connections between subsectors will always be accompanied by speed control, indicated in the Road Book and on the Stella III equipment.

The difference between Neutralization and Transfer is as follows:

Neutralization– it is not possible to carry out any intervention on the vehicle (park closed regime), including the vehicle itself and other competitors.

Transfer– it is possible to intervene on the vehicle, by the driver himself, by another driver still in the race or by Service as long as the official itinerary coincides with the Transfer zone.

ART.21 – SAFETY

21.1 Retirement / Exclusion

- a) In case of abandonment, the pilot must notify the organization, by any means and as quickly as possible, or via the SOS telephone number indicated on the bracelet.
- b) A driver who is disqualified or who has withdrawn must abandon the race and remove the competition numbers from the vehicle, handing the withdrawal letter to the First Race Official he finds. Failure to comply with this fundamental rule of
- c) security implies the payment of a fine of €100, and likely disciplinary sanctions applied by the FMP.

- d) For whatever reason, and particularly in the case of a pilot's withdrawal, Service is prohibited from entering the race route before the Sector involved has been considered open (finished).

21.2 Opening of the route

After competitors have passed, organization vehicles will open the track and provide transportation to drivers whose vehicles are damaged. Drivers who refuse to take a seat in the sweeper car will do so on their own responsibility. Under no circumstances will the organization be responsible for the repair, security or towing of participants' damaged vehicles.

21.3 Stella Competitor Location System III / Overtaking System for SSV, Motorcycle and Quad and Speed Control

It is mandatory to use the ANUBE Stella III location and speed control system.

This system allows checking the position of each driver on the route and speed control in the places mentioned by the organization, in addition to the overtaking system.

The equipment has a rental cost included in the registration.

The equipment also allows checking the stopping time of a pilot in the event of service to another injured pilot and removing this same time from that taken at the end of the race. To this end, the pilot in question must request in writing from the Race Director the correction of the same, decision of the Race Jury. This downtime will only be recovered if the reason for the stoppage is Service due to an accident and justified by the organization's resources that occur at the location.

In Baja de Portalegre, cars are also equipped with this system, which also allows for safe overtaking, if necessary, from cars to SSVs.

The rules for use are those described in the FMP regulations and in Appendix V of this same regulation.

- 21.4** A second piece of equipment will be distributed, Spica, these pieces of equipment must be carried by the pilots throughout the race, under penalty of 10 minutes for the infraction.

ART.22 – MEANS OF COMMUNICATION

- 22.1** The use of communications via the mobile phone system is authorized to contact the organizer in the event of an emergency, accident or withdrawal.

ART.23 – PARC FERMÉ

- 23.1** Refueling and repairs are prohibited in the Parc Fermé, except in the cases expressly provided for in the current Regulations.
- 23.2** Any infringement of the Parc Fermé regime will result in a Minimum penalty of 1 hour and up to disqualification.

- 23.3** After placing their vehicle in the park, the driver must immediately leave this location, and from then on their entry into the Park will be prohibited.
- 23.4** Before the start of any stage, riders are allowed to enter park 10 minutes before your departure time, to prepare the vehicle for departure.
- 23.5** Inside the Parque Fechado the Motorcycles, Quads and SSVs can move under the influence of the engine, as long as they do so at a maximum speed of 10 km/h and do not put the safety of third parties at risk.
- 23.6** Once the race is complete, vehicles can be removed from the Parc Fermé 30 minutes after the official classifications have been posted. In order for the driver to remove the vehicle from the Parc Fermé, he must go there with the bracelet still on and thus remove the vehicle with authorization from the commissioner.
If a representative is picking up the motorcycle, the rider, still with the bracelet on, must go to the Secretariat and fill out the form created for this purpose.
In exceptional situations, vehicles may be removed from the parc ferme before the scheduled time, but they are subject to any complaint, which will immediately result in disqualification.
- 23.7** The Parque Fechado will no longer be under the supervision and responsibility of the organization from 24:00 on November 28, 2023.

ART.24 – APPEALS / PROTESTS

- Protests about vehicles, according to article 27.1 of the RCNTT.
- Complaints about classifications, according to article 27.2 of the RCNTT.
- Appeal, according to article 27.3 of the RCNTT.

ART.25 – PRIZE LIST

25.1 General Classification

General Motorcycle Classification	1st to 10th classified	Cup or trophy
General Quad Classification	1st to 5th classified	
General SSV Classification	1st to 10th classified	

25.2 Classification by Category

1st MOTORCYCLE Category	<i>MTT1/MTT2/MTT3/MTT4/MTT5/VEM/VEQ</i>	Cup or trophy
1st QUAD Category	<i>Q</i>	
1st SSV Category	<i>SSV/ SSVTT2 / SSVSTOCK / SSV-E</i>	

25.3 Classification by Classes

Prizes will be distributed to the top 3 classified in each class, as long as there is a minimum number of 5 registered at the start, in accordance with Art. 34.3 of the FMP Regulations

1st to 3rd MOTO Class	<i>MP/MPS/MPV/MJ</i>	Cup or trophy
1st to 3rd Class QUAD	<i>QP/QPS/QPV/QJ</i>	
1st to 3rd Class SSV	<i>SSVPS/SSVPV/SSVJ</i>	

ART.26 – PRIZE GIVING CEREMONY

26.1 According to article 34 of RCNTT.

Procedure:

At the Podium Ceremony, on the entrance ramp to Nerpor's Parc Fermé, according to the race program, trophies will be symbolically handed out to the winners of the Moto, Quad and SSV Categories.

The awarding of prizes will take place in the administrative checks pavilion according to the program.

ART.27 – ENVIRONMENT

According to APPENDIX 8 of the RCNTT regulations.

APPENDIX I – ADVERTISING PLAN

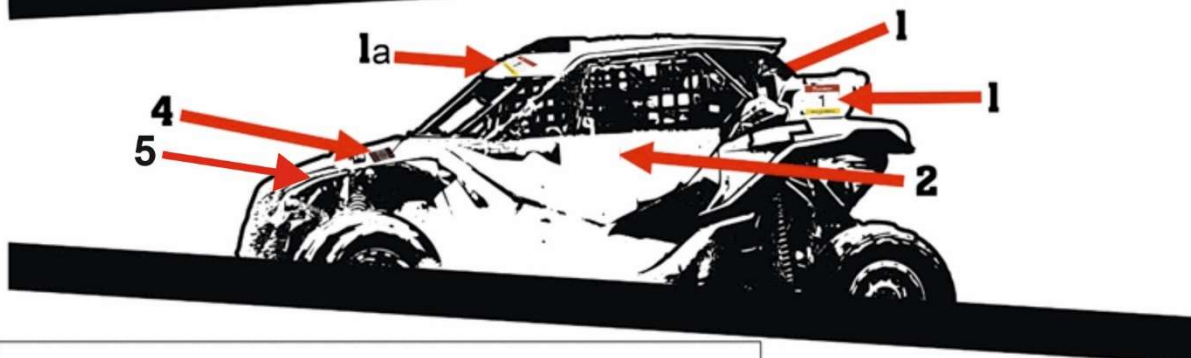
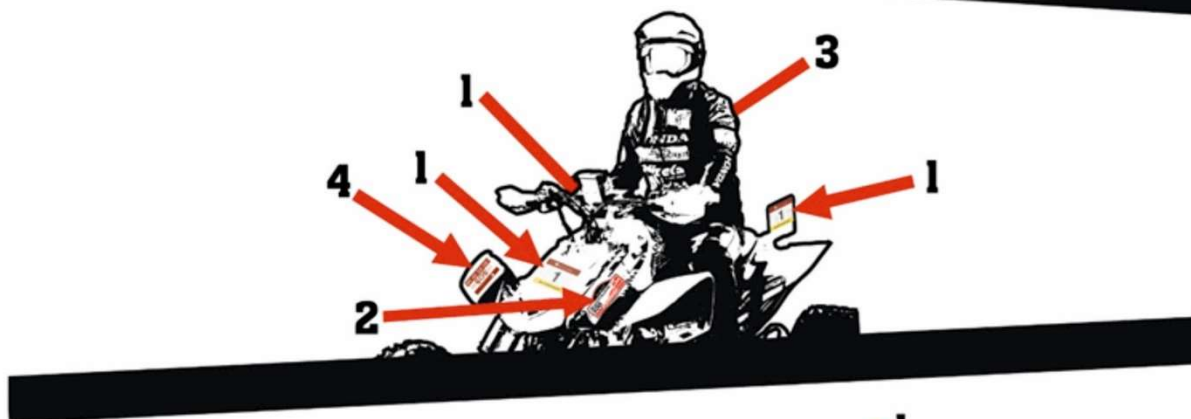

Legenda:

1 - 3 Paineis (20x10 moto/quad e 2 paineis 30x31 SSV com os números de prova

1a - Número de prova SSV (19x18)

2 - 2 Placas de Prova Moto/Quad - 2 Placas Publicidade SSV (30x31)

3 - 1 Dorsal (Moto e Quad)

4 - SOS - Deve ser colocado em local bem visível

5 - Placa de Prova SSV

4 AUTOMÓVEL CLUB DE PORTUGAL

TELEPHONE **SOS** EMERGÊNCIA
TELEPHONE **SOS** EMERGENCY

+351 912 201 545

APPENDIX II – COMPETITORS RELATION OFFICER (NAMES AND PHOTOGRAPHS)



Eduardo Rovisco
Cell phone (tba) +351

Tba
Cell phone (tba)

CRO's will be available by phone or email.

crobike.bajaportalegre@acp.pt



APPENDIX III – EQUIPMENT

1. All pilots must be equipped with:

The) Helmet approved by the FIM

B) Protective clothing made of resistant material that covers all limbs

w) Gloves

d) Competition boots suitable for each category

It is) Glasses

f) GPS (Anube)

g) Hans and fire-retardant clothing (SSV only)



APPENDIX IV – ITINERARY

Cerimonial Start							Thursday, October 17	
Sunrise - 07:42							Sunset - 18:46	
TC	LOCATION	SS km	Liason km	Total km	Time	1st. Moto		
V4	Parc Ferme IN (Jardim do Tarro)				*			
CS0	Cerimonial Start						19:00	
CS1	Nerpor		3,67	3,67	00:30 *		19:30	
totals		0,00	3,67	3,67				

STAGE 1							Friday, October 18	
Sunrise - 07:43							Sunset - 18:45	
TC	LOCATION	SS km	Liason km	Total km	Time	1st. Bike		
P0	START Section 1 / Stage 1 - NERPOR						07:25	
km 0,76/1,31 - Possible Refuelling (commercial filling stations indicated in the road book)								
P1	TC Start prologue		7,03	7,03	00:20		07:45	
SS1	Prologue	3,50					07:50	
ASS P	Prologue STOP (Max Time - 20m)			3,50			07:55	
km 69,59 - Possible Refuelling (refuelling provided by the team)								
km 70,35 / 70,70 - Possible Refuelling (commercial filling stations indicated in the road book)								
P1A	Regrouping IN Ponte de Sor		71,99	71,99	01:30 *		09:25	
0	Regrouping OUT - Start Section 2						09:55	
1	TC Start SS1		3,15	3,15	00:15		10:10	
SS1		60,00					10:15	
1A	SS1 Stop (Max Time 1h30m)			60,00			11:00	
km 0,96/27,91/28,49 - Possible Refuelling (commercial filling stations indicated in the road book)								
1B	Service Nerpor IN		28,98	28,98	01:00 *		12:00	
SERVICE A (NERPOR)		63,50	111,15	174,65	03:00			
1C	ARRIVAL Stage 1 / Parc Ferme Nerpor				03:00 *		15:00	
Stage 1 totals		63,50	111,15	174,65				

STAGE 2							Saturday, October 19	
Sunrise - 07:44							Sunset - 18:45	
TC	LOCATION	SS km	Liason km	Total km	Time	1st. Bike		
1D	START Section 3 / Stage 2 - NERPOR						08:25	
km 0,54/0,87/35,38 - Possible Refuelling (commercial filling stations indicated in the road book)								
2	TC Start SS2		38,92	38,92	01:15		09:40	
SS2		300,00					09:45	
2A	SS2 STOP (Max Time 4h35m)			300,00			13:45	
km 4,82/5,40 - Possible Refuelling (commercial filling stations indicated in the road book)								
2B	ARRIVAL Stage 2 / Parc Fermé Nerpor		5,99	5,99	00:30 *		14:15	
Leg 2 totals		300,00	44,91	344,91				

RALLY TOTALS				
	SS	Liason	Total	% SS
Leg 1 - SS1 / SS2	63,50	111,15	174,65	36,4%
Leg 2 - SS3	300,00	44,91	344,91	87,0%
Total	363,50	156,06	519,56	70,0%

* maximum time, check-in advance is authorized
V1 (30-07-24)

**APPENDIX V – GUIDELINES OF SECURITY AND LOCALISATION EQUIPMENT GPS/GSM
STELLA III**

MAIN SCREEN

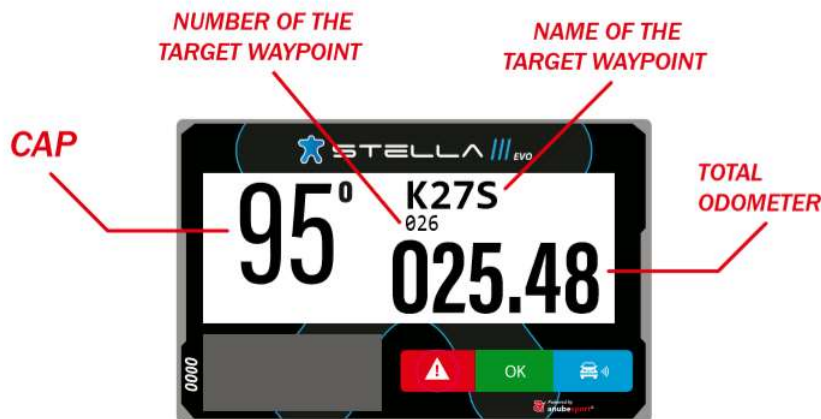

SPEED ZONE

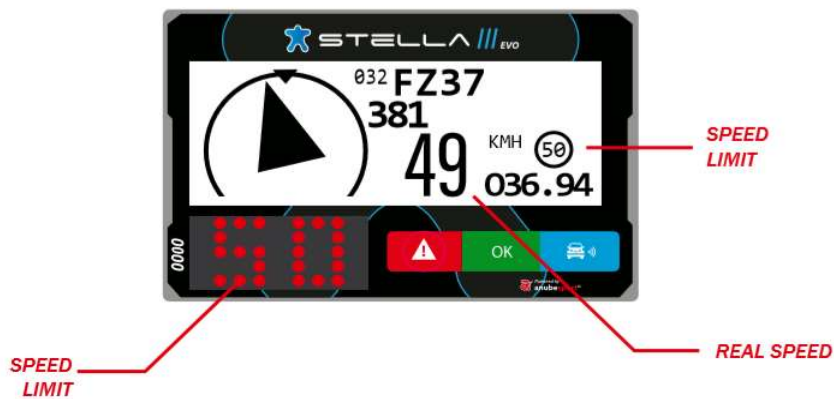

REQUEST MEDICAL ATTENTION IMMEDIATELY



SOS

1 sec.



CAUTION VEHICLE STATIONARY



3 sec.
 BREAKDOWN



DANGER 3 !!!



Notification 300m before an area marked in the roadbook as "Danger 3"

OVERTAKING / BLUE FLAG



OVERTAKING / BLUE FLAG



FLASHING

OVERTAKE REQUEST



STEADY



FLASHING



OVERTAKING / BLUE FLAG



FREE TO OVERTAKE



STEADY

PRESS THE BLUE BUTTON TO CONFIRM



SPEED LIMIT



SPEED LIMIT

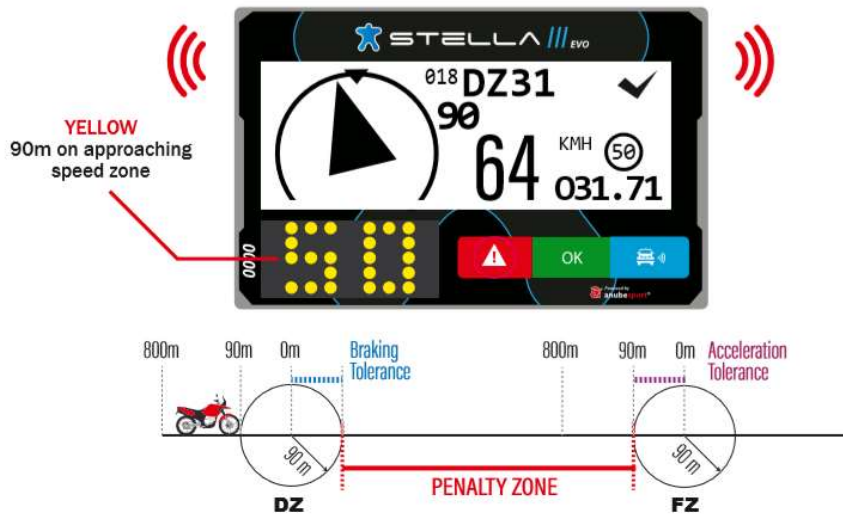

SPEED LIMIT

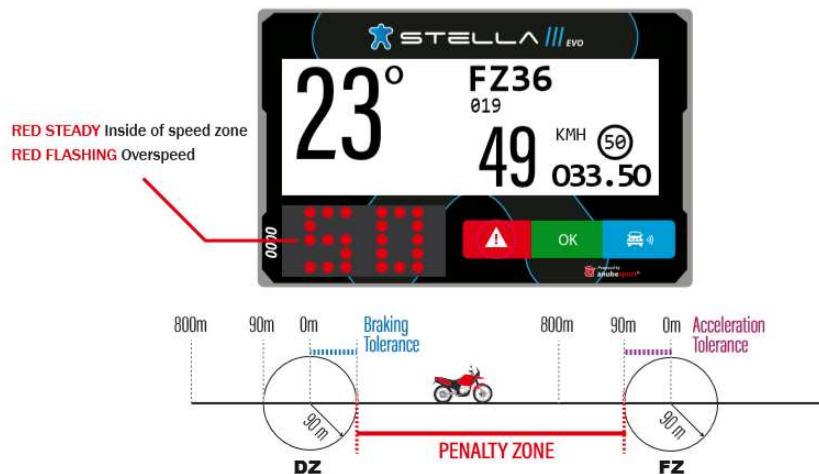

SPEED LIMIT

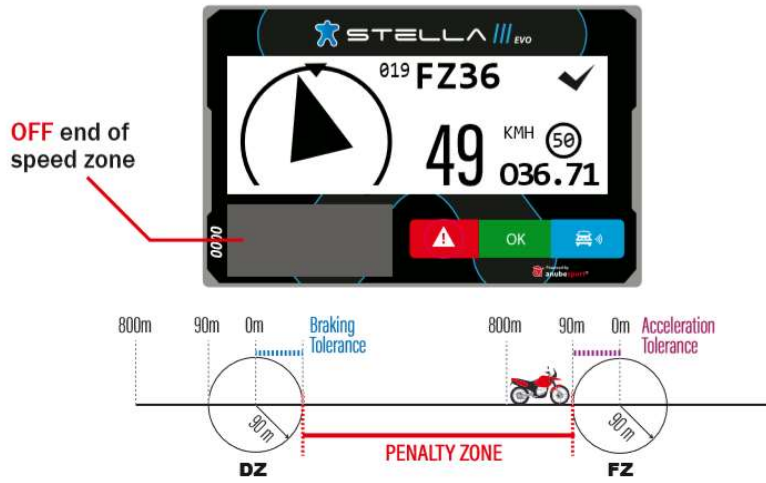

NEUTRALIZATION ZONE

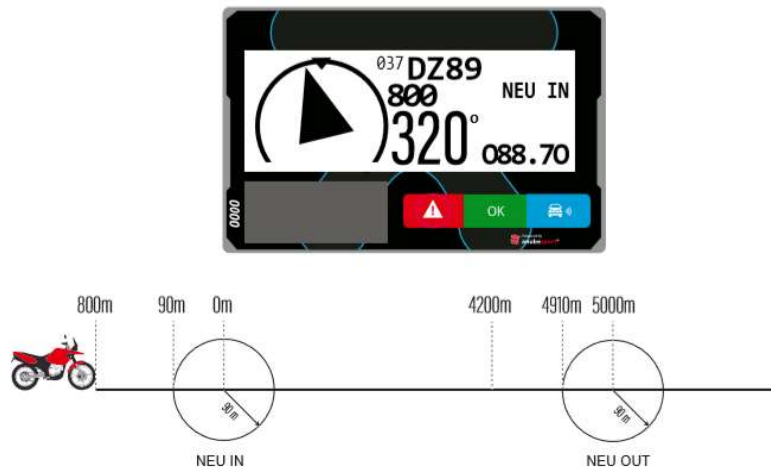

NEUTRALIZATION ZONE



WAYPOINTS LIST



OK



NEUTRALIZATION ZONE

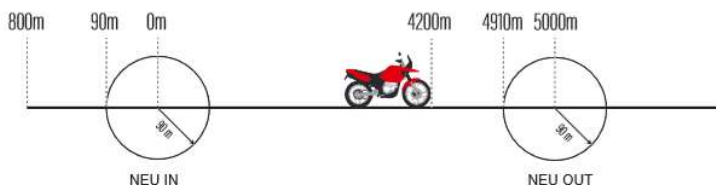

NEUTRALIZATION ZONE

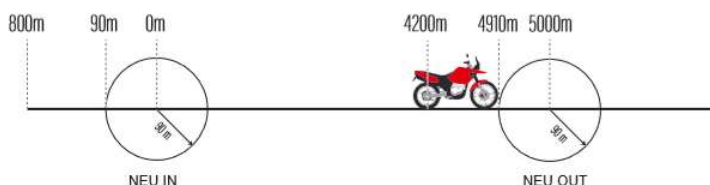

WAYPOINT PROXIMITY



TOTAL ODOMETER RESET TO ZERO



OK

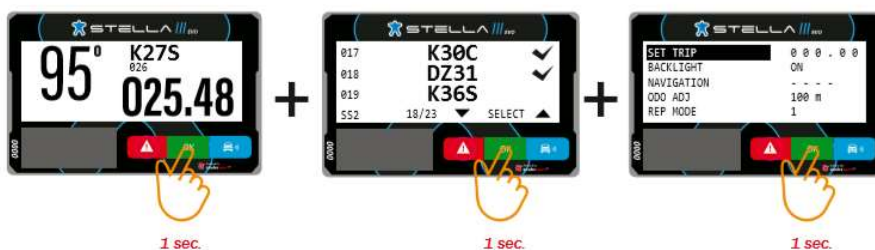

KIT for compulsory installation of STELLA III System



1 – Iridium Antenna / 2 – Power Cord / 3 – RF Cord / 4 – RF Antenna/ 5 – Base/Mount
6 – GPS Antenna / 7 – Adhesive / 8 – Straps / 9 – User Manual

IMPORTANT

For the functional test and verification, all vehicles must have through the installation of the mount, power cord, and antennas.

1. POWER CORD

- Connect the red wire to the positive end of battery 12V (+), and the grey wire to the negative (GRD). The power cord must be connected directly to the battery (without interruptions and without contact in the power supply).

- A 3A fuse (not included) should be connected to the red wire.

- Take the cord to the location in which the STELLA III EVO is to be installed. All other wires must be insulated, they cannot touch



2. BASE / MOUNT

ATV: The mount can be attached to the handle bar or to a metal plaque close to the navigation system.

- Car and SSV: The mount can be attached to the panel, or to the roll cage bars. STELLA III EVO buttons, must be visible and accessible to the participant (pilot/navigator) even when they are sitting and with the seatbelts buckled.

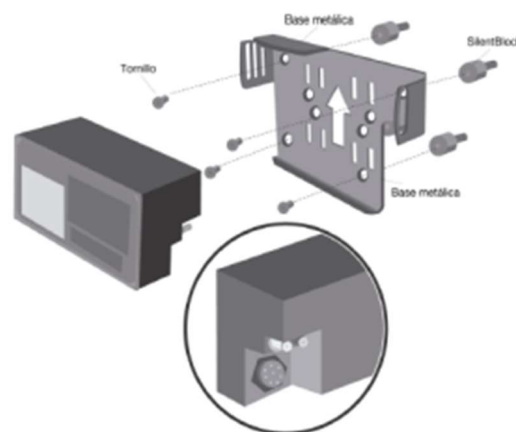

IMPORTANT

Leave the cords (antenna and battery) in place with at least 10 cm to spare for easy handling.
At least 5 cm of space behind the mount (bottom right corner) to allow space for power cord/connections.

3. GPS ANTENNA

- The GPS antenna must be installed horizontally and without obstructions toward the sky. In cars and SSV, it can be mounted on the roof, the hood, or the dashboard. In ATV, attach to the mudguard. For additional firmness, it is recommended to cover it with adhesive tape (non-metallic when mounting it to a metallic surface) and pull-up (when attached to soft or plastic parts).



4. IRIDIUM ANTENNA

The Iridium antenna must be installed horizontally and without obstructions toward the sky. In cars and SSV, it can be mounted on the roof, the hood, or the dashboard. In ATV, attach to the mudguard. For additional firmness, it is recommended to cover it with adhesive tape (no metallic when mounting it to a metallic surface) and pull-up (when attached to soft or plastic parts).



THE USE OF THE TRACKING SYSTEM & ACCIDENT RESPONSE & CAR-TO-CAR COMMUNICATION SYSTEM 5. GPS ANTENNA

The radio-frequency antenna must be installed vertically to the roll cage bars (cars and SSV) and the forks (ATV). It is mandatory to use separators (included in the kit) to avoid contact with metallic parts and the carbon fibre that surrounds it.

Once the antennas are mounted, take the SMA connection cords to the base/mount where the STELLA III EVO will be installed.



APPENDIX VI – SECURITY PLAN

1 – Location of the race control



Location: Nerpor (Portalegre)

39°16.389'N / 7°25.271'W

The race control will provide the hub for receiving data transmission from the selective sections that relates to any safety matters.

This centre will be equipped with three bearer systems for data concerning safety and sporting matters:

- Radio Communication equipment (multi-channel)
- Mobile telephones operating on GSM network
- GPS-GSM System

2 – Key personnel

- **Clerk of the Course Cars**
Horácio Rodrigues – Tel. +351 917 582 729
- **Assistant Clerk of the Course Cars**
Jaime Santos – Tel. +351 917 343 864
Filipe Gaivão – Tel. +351 919 081 560
Orlando Romana – Tel. +351 917 289 861
- **Clerk of the Course Bikes**
Márcio Santos – Tel. +351 963 828 737
- **Assistant Clerk of the Course Bikes**
Nelson Correia – Tel. +351
Eduardo Rovisco – Tel. +351
- **Chief Medical Officer**
Dr. Pedro Barradas – Tel. +351 964 065 446
- **Chief Security Officer**
Jaime Santos – Tel. +351 917 343 864

3 – Safety officers in charge of safety for each selective section

- SS1 – Luis Marcão – Tel. +351 919 702 443
- SS2 – Filipe Viçoso – Tel. +351 962 743 385
- SS3 – Carlos Calhau – Tel. +351 963 173 720
- SS4 – Luis Marcão – Tel. +351 919 702 443

4 – Safety services in the area of each selective section

- Police (PSP) – Tel. +351 245 300 620
- National Guard (GNR) – Tel. +351 245 331 603
- Hospitals – José Maria Grande (Portalegre) – Tel. +351 245 301 000
– Abrantes – Tel. +351 241 360 700
- Towage – ACP – Tel. +351 707 509 510

5 – Radio communication system

Four radio channels under Race Control supervision

- Channel 1 – Organization
- Channel 2 – Passage controls
- Channel 3 – Radio Points
- Channel 4 – Medical Team

6 – Medical equipment available

- 1 Medical Helicopter, with one Doctor
- 6 medical Teams, of one Doctor and one paramedic on 4Wheel Drive vehicles
- 10 ambulances
- 1 Medical Centre on Nerpor

7 – Location of the medical vehicles

- On the special stages, there will be one medical vehicle every 40 km's (minimum).
- One medical vehicle at the start and at the arrival of each special stage (or the Medical Assistance is given by the Medical Centre)

8 – Location of the passage control vehicles

In each special stage there will be:

- A car equipped with radio every 15 km (average)

Every intersection with an asphalt road will be monitored together with the police

9 – Safety of the crews

All competition vehicles will compulsorily be equipped with a tracking system.

10 – Rescue equipments

Medical Vehicles

- 4 wheel drive vehicles
- with a Team of one Doctor and one Paramedic on board
- with a fuel capacity for 400 Km
- with a reserve of drinkable water for the Competitors
- with the possibility to transport an injured person lying down
- with 1 radio in permanent contact with the Race Control
- with 1 mobile phone

Rescue Equipment of the Medical Vehicles

- 1 “reanimation box”;
- Intubations material;
- Urgent indictable;
- Diagnostic material;
- 1 survival mattress;

Medical Helicopter Equipment

Similar equipment as the medical cars

- 1 portable suction machine;
- 1 respiratory fan;
- 1 Doctor qualified in reanimation

Medical Centre

Similar equipment as the vehicles and Helicopter, and also:

Material:

- 1 tent
- supplementary medications and material
- 1 stretcher

Specialized Persons

- 1 Chief Doctor
- 1 Doctor qualified in reanimation
- 1 Paramedic

11 – Closing of the route

An Organization “sweeper” vehicle will close the route of the event, as notified in the road-book.

This vehicle will pick up the people whose vehicle is broken down or out of service, but in no case, broken-down vehicles will be towed.

Drivers who refuse to be transported by the sweeper vehicle do so under their own responsibility, and they must sign a discharge that will be handed to them by the route-closing members of the organization.

No claim based on the consequences of this refusal may be directed against the Organization. In case of retirement due to a mechanic failure on the special stage, the competitor must wait for the sweeper vehicle.

12 – Safety of the public

In all spectators areas there will be a team of the Organisation, with radio, and the National Guard (GNR). Both on close contact with the Chief Safety Officer, for any reinforcement needed.

13 – Safety of the officials of the event

Members of the Organisation, using mobile phones, will accompany all Officials.

Some additional information will be given, to the Officials of the Event, on October 26th:

- 1 – Programme
- 2 – Itinerary (map of controls)
- 3 – Rally officials phone numbers
- 4 – Emergency Phone numbers
- 5 – Safety Plan description
- 6 – Maps – Bivouac and HQ
- 7 – Maps – each SS and the Spectators areas
- 8 – Safety Plan synopsis
- 9 – Time average of competitor’s in each SS
- 10 – Radio Network
- 11 – Official authorizations granted
- 12 – Hospitals and medical centres on duty
- 13 – Insurance of the event
- 14 – Environmental policy

APPENDIX VII – NERPOR LAYOUT

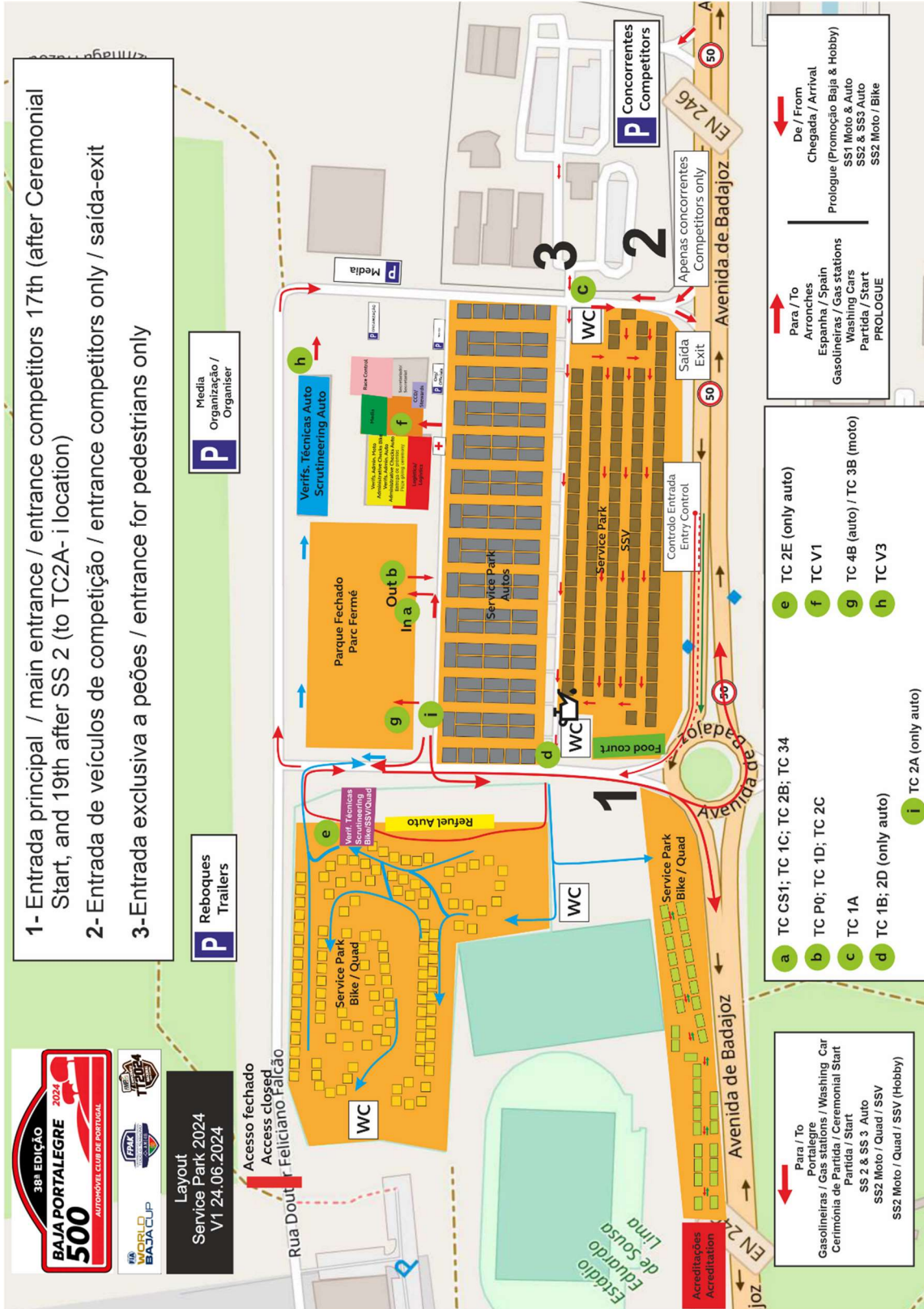



APPENDIX VIII – ENVIRONMENTAL POLICY

Tba



**AUTOMÓVEL
CLUB DE PORTUGAL**

Rua General Humberto Delgado, 3
2685 - 340 PRIOR VELHO
Tel: 351 219 429 187 Fax: 351 219 429 192
acpmotorsport@acp.pt



50